

Typ 101 Type 101

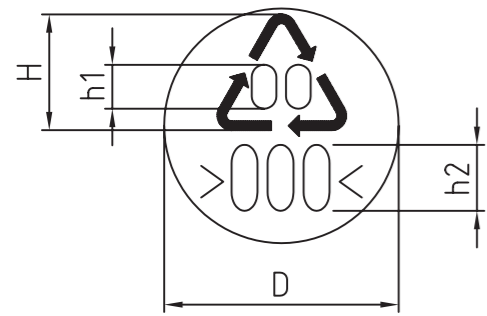

Bestellbeispiel nächste Seite
 Ordering example see next page

Zusatzbezeichnung Additional designation	Kunststoffart Type of plastic
01	PET
02	PE-HD
03	PVC
04	PE-LD
05	PP
06	PS
07	andere others

Maßtabelle in mm Dimension table in mm				
D	H	h1	h2 bis 3 Zeichen h2 up to 3 chars	h2 bis 5 Zeichen h2 up to 5 chars
4	2,1	0,7	0,8	0,75
5	2,6	0,9	1,05	0,95
6	3,16	1,15	1,3	1,15
8	4,4	1,5	1,7	1,5
10	5,5	1,9	2,1	1,9
12	6,2	2,3	2,6	2,3
16	8,3	3,1	3,4	3,1
20	10,4	4,0	5,0	4,0
30	16,0	6,0	7,7	6,0
40	20,7	7,7	8,8	7,7

Elektrode Nr. 1-101 Electrode No. 1-101

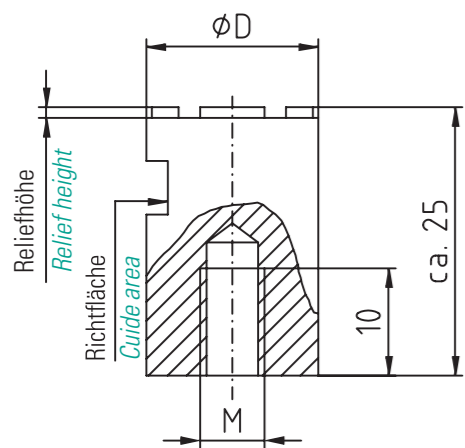

Beschriftung
lesbar erhaben
Characters
legible raised

Material:
Erodierkupfer
Material:
copper

Maßtabelle in mm Dimension table in mm			
D	M	Reliefhöhe Relief height	Euro
4	/	0,4	36,00
5	3	0,5	36,00
6	4	0,5	36,00
8	4	0,5	36,00
10	4	0,5	36,00
12	6	1,0	39,00
16	6	1,0	39,00
20	6	1,0	49,00
30	8	1,0	69,00
40	8	1,0	80,00

Sondergrößen nach Wunsch Special variables as required

Einsatz Nr. 2-101 Insert No. 2-101

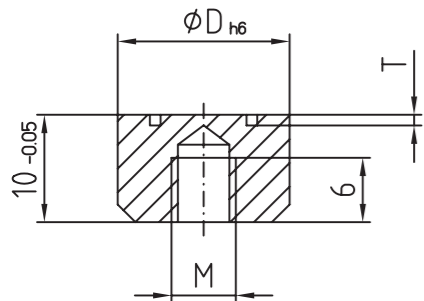

Beschriftung
spiegelbildlich vertieft
Characters in
mirror writing recessed

Material: 1.4034
ca. HRC 56 ± 2 rostfrei
Material: 1.4034
approx. HRC 56 ± 2 stainless steel

Maßtabelle in mm Dimension table in mm			
D	M	T	Euro
4	2	0,2	19,00
5	3	0,2	19,00
6	4	0,2	19,00
8	4	0,2	19,00
10	4	0,2	19,00
12	6	0,25	20,00
16	6	0,3	20,00

Sondergrößen nach Wunsch Special variables as required

Einsatz Nr. 3-101 Insert No. 3-101

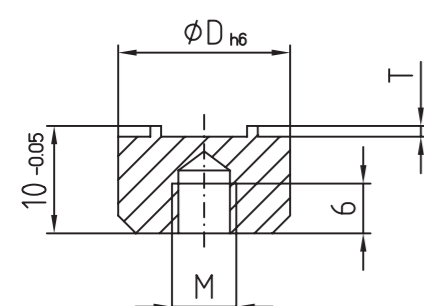

Beschriftung
spiegelbildlich erhaben
Characters in
mirror writing raised

Material: 1.4034
ca. HRC 56 ± 2 rostfrei
Material: 1.4034
approx. HRC 56 ± 2 stainless steel

Maßtabelle in mm Dimension table in mm			
D	M	T	Euro
4	2	0,2	35,00
5	3	0,2	35,00
6	4	0,2	35,00
8	4	0,2	35,00
10	4	0,2	35,00
12	6	0,25	38,00
16	6	0,3	42,00

Sondergrößen nach Wunsch Special variables as required

Auswerfer Nr. 4-101 Ejector pin No. 4-101



Beschriftung
spiegelbildlich vertieft
Characters in
mirror writing recessed

nach DIN / ISO 6751
Material: Warmarbeitsstahl
pursuant DIN / ISO 6751

Länge L Length L				-100 mm	-200 mm	-315 mm
D	d	k	T	Euro	Euro	Euro
5	10	3	0,2	59,00	59,00	59,00
6	12	5	0,2	60,00	60,00	60,00
8	14	5	0,2	61,00	61,00	61,00
10	16	5	0,2	62,00	62,00	62,00
12	18	7	0,25	64,00	69,00	72,00
16	22	7	0,3	69,00	79,00	82,00

Sondergrößen nach Wunsch Special variables as required

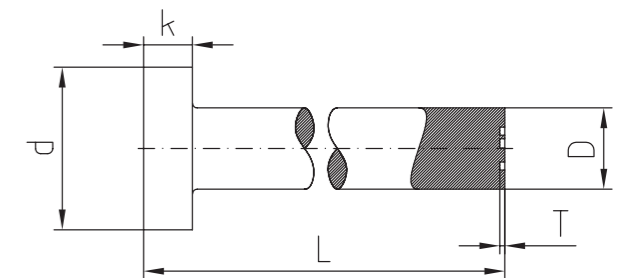

Bestellbeispiel Example order:

4-101-10-PVC-L=110,3
entspricht Auswerfer Ø 10 mit Länge 110,3
corresponds ejector pin with diameter 10 with length 110,3

Auswerfer Nr. 5-101 Ejector pin No. 5-101



Beschriftung
spiegelbildlich erhaben
Characters in
mirror writing raised

nach DIN / ISO 6751
Material: Warmarbeitsstahl
pursuant DIN / ISO 6751

Länge L Length L				-100 mm	-200 mm	-315 mm
D	d	k	T	Euro	Euro	Euro
5	10	3	0,2	65,00	65,00	65,00
6	12	5	0,2	66,00	66,00	66,00
8	14	5	0,2	69,00	69,00	69,00
10	16	5	0,2	70,00	70,00	70,00
12	18	7	0,25	72,00	76,00	80,00
16	22	7	0,3	76,00	86,00	89,00

Sondergrößen nach Wunsch Special variables as required

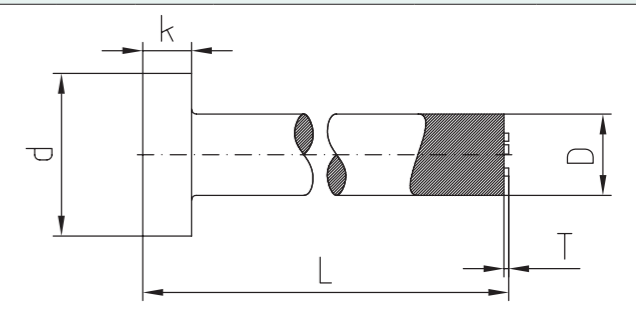

Bestellbeispiel Example order:

4-101-10-PVC-L=110,3
entspricht Auswerfer Ø 10 mit Länge 110,3
corresponds ejector pin with diameter 10 with length 110,3

Bestellbeispiel Example order:

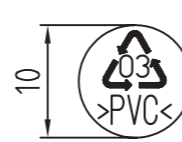

Elektrode: *Electrode:*
Einsatz vertieft: *Insert recessed.*
Einsatz erhaben: *Insert raised.*
Auswerfer vertieft: *Ejector pin recessed.*
Auswerfer erhaben: *Ejector pin raised.*

1-101-10-PVC
2-101-10-PVC
3-101-10-PVC
4-101-10-PVC-L=110,3
5-101-10-PVC-L=110,3